

# HYBRID RESISTOR NETWORKS

## (DESIGN YOUR OWN NETWORK)

We can manufacture the network as per your needs in the hybrid format when it is not possible for technical reasons to manufacture it in the monolithic form. You can choose to have a hybrid with any combinations of monolithic resistors, thin film chip resistors and / or thick film high value chip resistors.

The monolithic resistors will be made by patterning and trimming the NiCr film deposited on alumina substrate and the conducting traces formed by deposited copper. Chip resistors are selected as per your specified value, tolerance and tcr and are then soldered onto the substrate. The ratios of tolerance and TCR tracking are tested on the chip before epoxy coating. Any combination within the manufacturing and testing capability can be supplied.

### APPLICATIONS & ADVANTAGES:

Hybrid networks have the advantage of taking up considerably less space and offer the advantages of high accuracy, tight TCR matching and good temperature tracking compared to discrete resistors. They allow the use of more precise resistors and are often less expensive to build in small numbers. Typical applications are in Analog Circuits, Testing and measuring instruments, Industrial Instrumentation etc.

### DIMENSIONS :

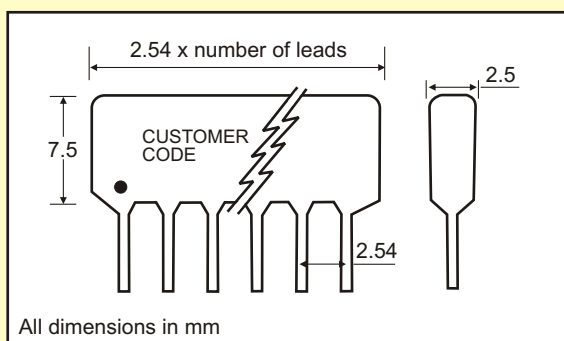

### MECHANICAL SPECIFICATION:

Number of pins	3 to 16 Single in Line
Substrate Material	Alumina
Resistive Material	NiCr with thin and/or thick film chip resistors
Body	Powder Epoxy Coated
Terminals	Lead Frame with 0.1" spacing
Marking	As per customer given code

### ELECTRICAL SPECIFICATIONS:

There is nothing standard about these hybrids everything depends on what **you** design.

The following parameters are just for your guidance.

Values between	: 10 $\Omega$ to 10 M
Absolute Tolerance	: 0.1%, 0.5%, 1%, 5%
Ratio Tolerance	: down to 0.05% (depends on values and absolute tolerance)
Absolute TCR	: $\pm 5$ , $\pm 10$ , $\pm 15$ , $\pm 25$ , $\pm 50$ ppm/ $^{\circ}\text{C}$
TCR Tracking	: down to $\pm 5$ ppm/ $^{\circ}\text{C}$
Operating Temperature Range	: $0^{\circ}\text{C}$ to $+75^{\circ}\text{C}$
Insulation Resistance	: 10,000M $\Omega$

### DESIGN ASSISTANCE :

For assistance on the customized precision resistor network configuration that can best meet your needs just email us your rough schematic and we will be pleased to provide design with technical assistance and pricing information.

# INTRON

## Integrated Electronics Technology Pvt. Ltd.

A -218, Road No. 16/V, Wagle Industrial Area, Thane 400 604. India  
Tel: +91 22 25821053 Fax: +91 22 25822162  
email: intron@vsnl.com / intron@mtnl.net.in

[www.intronresistors.com](http://www.intronresistors.com)